

commercial 3100IM

The **3100IM Commercial Series** is our certified windload rated, rolling sheet door that meets specified wind loads required by even the most stringent building codes. Independent laboratory testing proves the strength and durability of the 3100IM series. The quick installation and smooth operation, compared to other doors, further demonstrates how user friendly this door is. Backed by a one-year warranty, it's no wonder this 3100IM series is so popular.



Maximum
16' x 18'

Available in sizes up to 16' x 18' and in more than 30 colors, customized for your application.



Medium-Duty
Application

Ideal for medium-duty locations, such as warehouses, commercial buildings, and freight terminals.



Wind Load
Rated

Superior construction and innovative design make this door able to withstand heavy winds and extreme weather.



Impact
Rated

Approved by the Florida Building Code. ANSI/DASMA 115 impact and cyclic.



Quality
Guaranteed

One-year door warranty. For paint, 35-year no-fade, 40-year film integrity.



Features

- » **Pre-Lubricated Springs**
During production, springs are factory lubricated and enclosed in a tube to protect them from the environmental elements.
- » **Dead Axle & Barrel Assembly**
An enclosed spiral barrel houses the dead axle assembly and offers durability and smoother operation as weight is distributed throughout the barrel.
- » **26-Gauge Corrugated Door Curtain**
Manufactured from galvanized grade 80 steel and coated with super durable polyester paint in more than 30 color options.
- » **Insulated Version Available**
Side and top draft stops included.

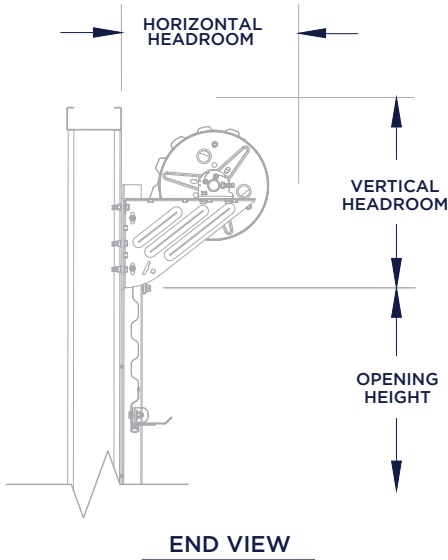

IMPORTANT NOTES:

- Dimensions are referenced from edge of opening.
- Tensioner end and drive end can be installed at either end of door assembly.
- FOR CRITICAL FITS DUE TO REDUCED AVAILABLE HEADROOM or SIDEROOM CLEARANCES, CONSULT FACTORY.

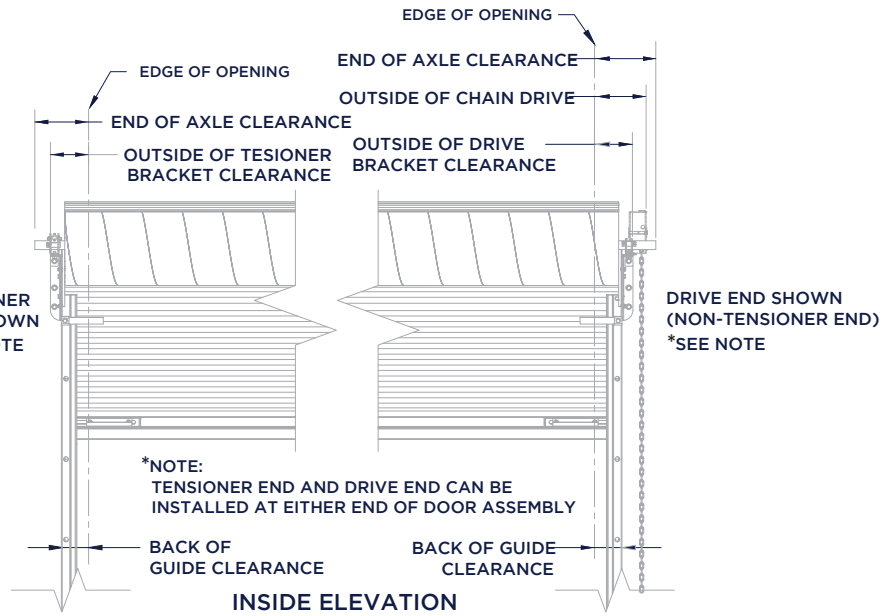

Universal mount 4" deep 12-gauge galvanized steel wind bar guides require no pre-installation modifications for steel, concrete or filled masonry block applications.

SPECIFICATIONS

Guide Details

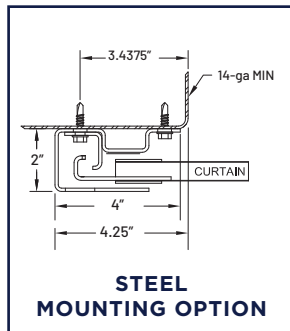
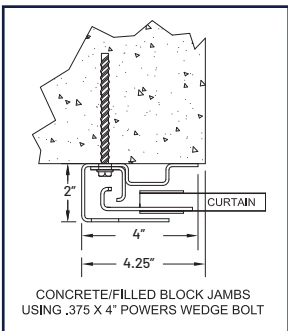

Steel mounting options are limited to the option shown above. Wood and filled block mounting options are not pictured.

Contact the manufacturer about additional jamb materials.

*Steel Jambs 14-gauge MINIMUM for opening widths less than or equal 14'.

Head Room Requirements

Opening Height	Vertical Headroom	Horizontal Headroom
Thru 8'0"	20"	20"
Thru 10'0"	21"	21"
Thru 14'0"	23"	23"
Thru 16'0"	24"	24"
Thru 18'0"	25"	25"
Thru 20'0"	26"	26"

HIGHLIGHTS:

- B** Barrel: 12"
 - G** Guide: 4", 12-gauge
 - 5:7:1 reduced-drive chain hoist offers smoother operation on doors over 10' tall.
- Visit JanusIntl.com for technical drawings, color options and more.

Side Room Requirements

Operation	Guide	Outside of Bracket Tensioner End	Outside of Hand Chain Drive	Outside of Bracket Drive End	Each End of Axle
Push Up	4.25"	6.25"	N/A	6.25"	10.5"
Reduced Drive Chain	4.25"	6.25"	8.75"	10"	10.5"
Electric	4.25"	6.25"	N/A	10"	10.5"

PLEASE VISIT OUR WEBSITE FOR ADDITIONAL INFORMATION:

- ADA Compliance
- Color Options
- Installation
- Technical Drawings
- Warranty
- Additional Locations

Austin Building Systems
Call 888-399-6079
buildmetal.com